

**Grease separator Euro "D" according to EN 1825-1
NS 2/4/7/10 with direct disposal**
for free standing installation in frost free areas

Illustration



Art. # 93 002.00 / D1 Version in flow direction right

Article description

KESSEL Grease separator Euro "D" NS ...
with direct disposal, according to EN 1825,
made of polymer

For free standing installation in frost free areas,
with integrated sludge trap, domed cover made of polymer,
with snap closures and sealed odor-tight, with installed suc-
tion system in flow direction left or right for disposal both
from the sludge trap and the grease separating chamber,
with flange connection for intake pipe, disposal flange \varnothing 65,
PN 10 according to DIN 2501,
Storz-B-Coupling R 2 1/2 for connection to disposal trucks.
Inlet and outlet \varnothing ... for synthetic material pipes in:
PE-HD (according to DIN 19537); PP, AS or HT according
to DIN 19560.

Sludge trap content: Liter Manufacturer: KESSEL
Separator content: Liter Artikel #:
Weight: kg **Certification no. Z-54.6-327**

Delivery: System completely assembled.
On-site welding available on request.

+ Accessories

Inspection window in flow direction left/right see Page A 10.
Inlet left/right R1 see Page A 10.
Sampling chamber see Page A 10.
Lifting stations see Page A 11.

Installation site	Nominal size	Weight approx.	Art. #	Scope of delivery
for free standing installation in frost free areas	NS 2*	54 kg	Disposal pipe connection right** 93 002.00 / D1	Container with domed covers, piping complete with disposal pipe connection
	NS 4*	69 kg	93 004.00 / D1	
	NS 7*	104 kg	93 007.00 / D1	
	NS 10*	129 kg	93 010.00 / D1	
	* other sizes available on request			

Dimensioned illustration

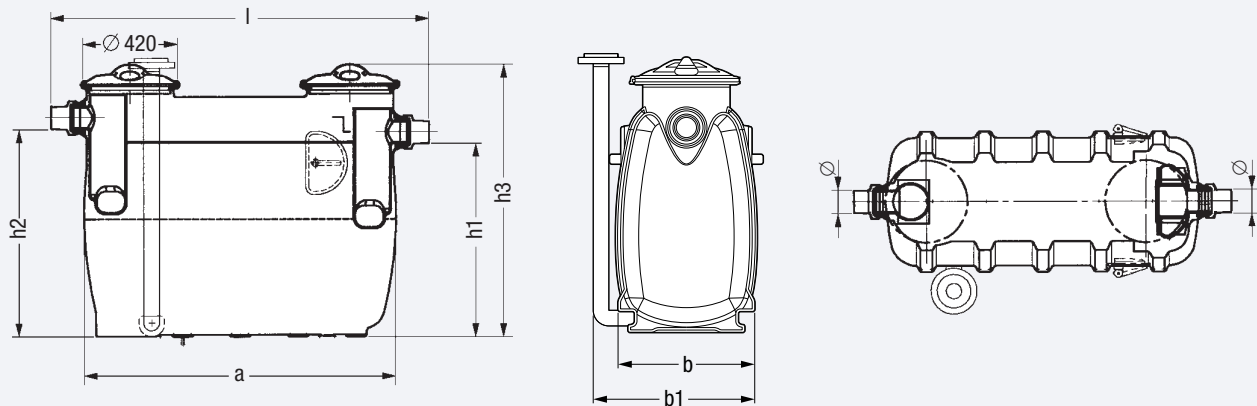

\varnothing = Outer diameter b1 = Installation dimensions

Nominal size	\varnothing	a	Access opening			b1	h1	h2	h3	Wastewater content		Grease separator
			l	x	b					Sludge trap	Separator	
NS 2	110	1030	1250	670	840	930	1000	1310	200 l	212 l	106 l	
NS 4	110	1500	1810	730	840	930	1000	1310	400 l	354 l	177 l	
NS 7	160	1600	1850	990	1080	1130	1200	1560	700 l	567 l	302 l	
NS 10	160	2430	2700	990	1080	1130	1200	1560	1000 l	794 l	423 l	

** Disposal pipe connection on the left available on request