

Two-piece toilet # 011701..62

|< 350 mm >|

D-Code

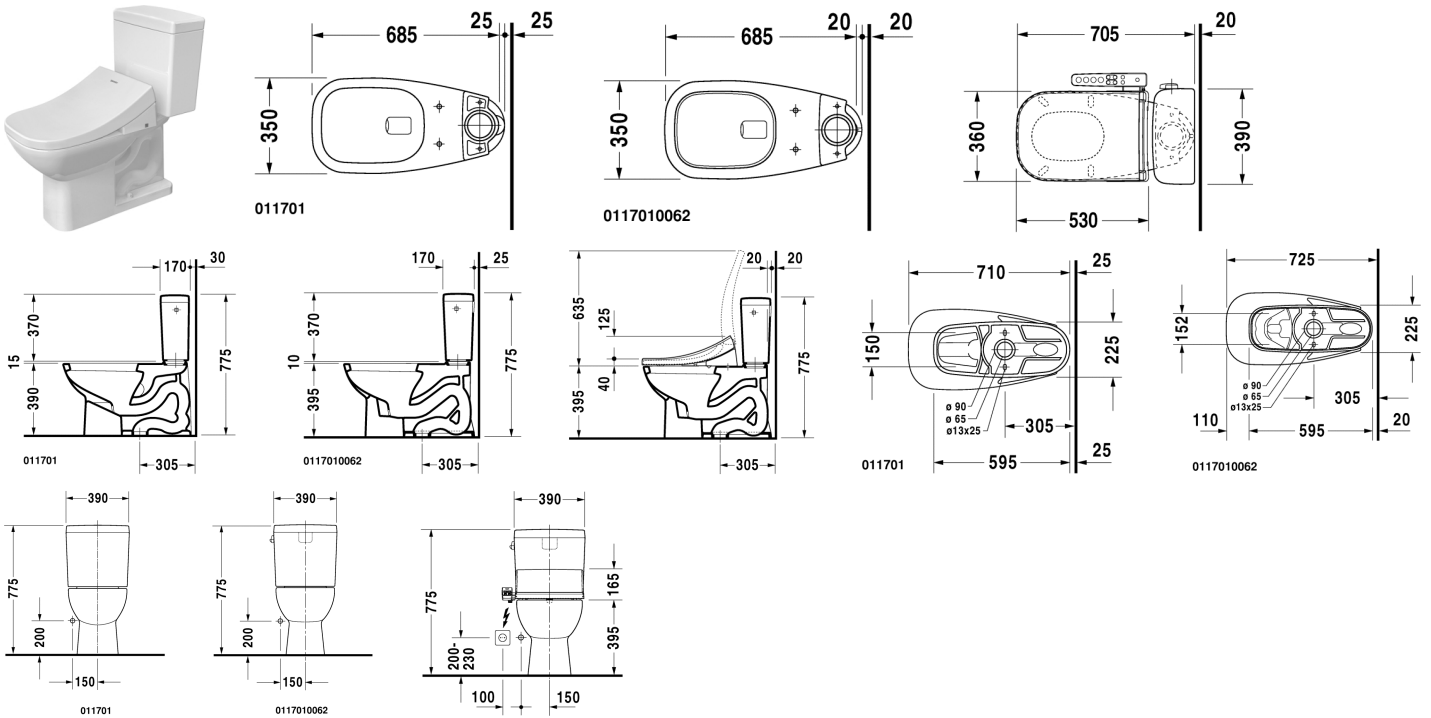

Two-piece toilet	Dimension	Weight	Order number
(without cistern), US-version, elongated with syphonic jet action, 305 mm/12" rough-in, IAPMO listed, vertical outlet			
Colors			
00 White Alpin			
Variant			
	350 x 685 mm	26,200 kg	011701..62
Accessories			
Cistern	385 x 170 mm	12,000 kg	092720
Cistern	385 x 170 mm	12,000 kg	092720
Toilet seat and cover	-	2,500 kg	006741
Toilet seat and cover	-	2,500 kg	006741
Toilet seat and cover	-	2,500 kg	006209
Toilet seat and cover	-	2,500 kg	006209
Mounting set	-	0,480 kg	001431
Mounting set	-	0,480 kg	001418
Fixing			
Mounting set	-	0,480 kg	001431
Mounting set	-	0,480 kg	001418

REMINDER:	Pipe flushing must be done before faucets are installed. Failure to do so voids the warranty.
	Do not use cleaners containing abrasive cleansers, ammonia, bleach, acids, waxes, alcohol, solvents or other products not recommended for chrome.
	All information is for reference only, installation shall always be based on the actual product delivered.