



Brand : TEKA, Spain
Name : ELECTRIC MODULAR HOBS / Built-in electric modular hob EM/30.2P

Item Code : 1020.9611
Color/Finish: Inox Steel
Dimensions : Overall (LxWxH in cm)
30 x 50 x 4cm

Product info:

- Modular electric hob
- Stainless steel frame
- Metal looking frontal knobs
- 2 cooking zones:
 - 1 electric plate 180mm \varnothing (1.5 kW)
 - 1 electric plate 145 mm \varnothing (1.5 kW)
- Voltage: 220V / 50~60 Hz
- Wattage: 3000 watts
- Phase: single+grounding

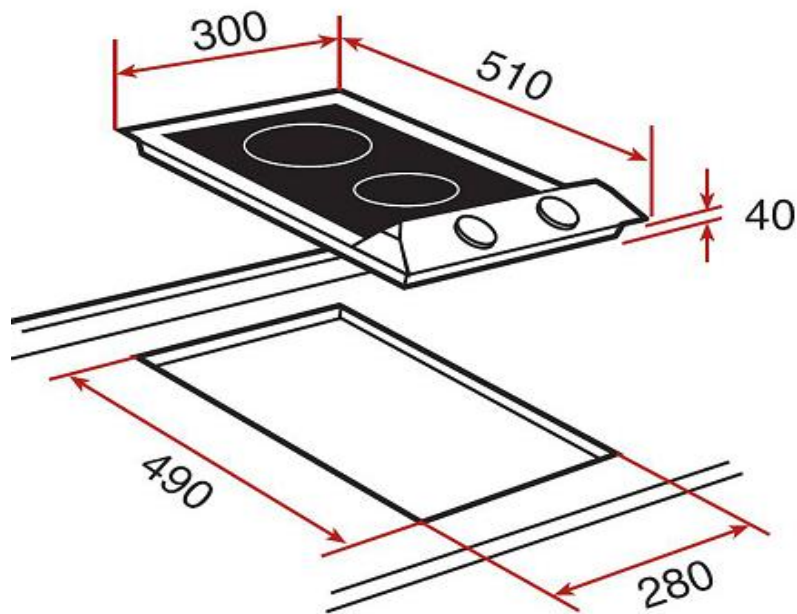

ATTENTION: Cut hole must be with round corners in order to avoid cracking on the counter-top.

Follow cleaning instructions and avoid using any harmful chemicals.

All information is for reference only. Installation shall always be based on the specs provided with actual delivered items.

For more info, visit www.kuysen.com