

SPECIFICATION SHEET - fittings

| | |
|---------------------------------|---|
| BRAND: | AXOR® |
| ORIGIN: | Germany |
| SERIES: | Citterio E |
| PRODUCT DESCRIPTION: | Shower set 0.90m with handshower 120 3jet <ul style="list-style-type: none"> • spray type: Rain, RainAir, WhirlAir • maximum flow rate: 15 l/min at 0.3 Mpa • shower head size: 125mm |
| MODEL No. | 36735.000 |
| FINISH/COLOUR: | Chrome-plated |
| DIMENSIONS: | 1009mm bar height |
| OPTIONAL MATCHING PARTS: | |

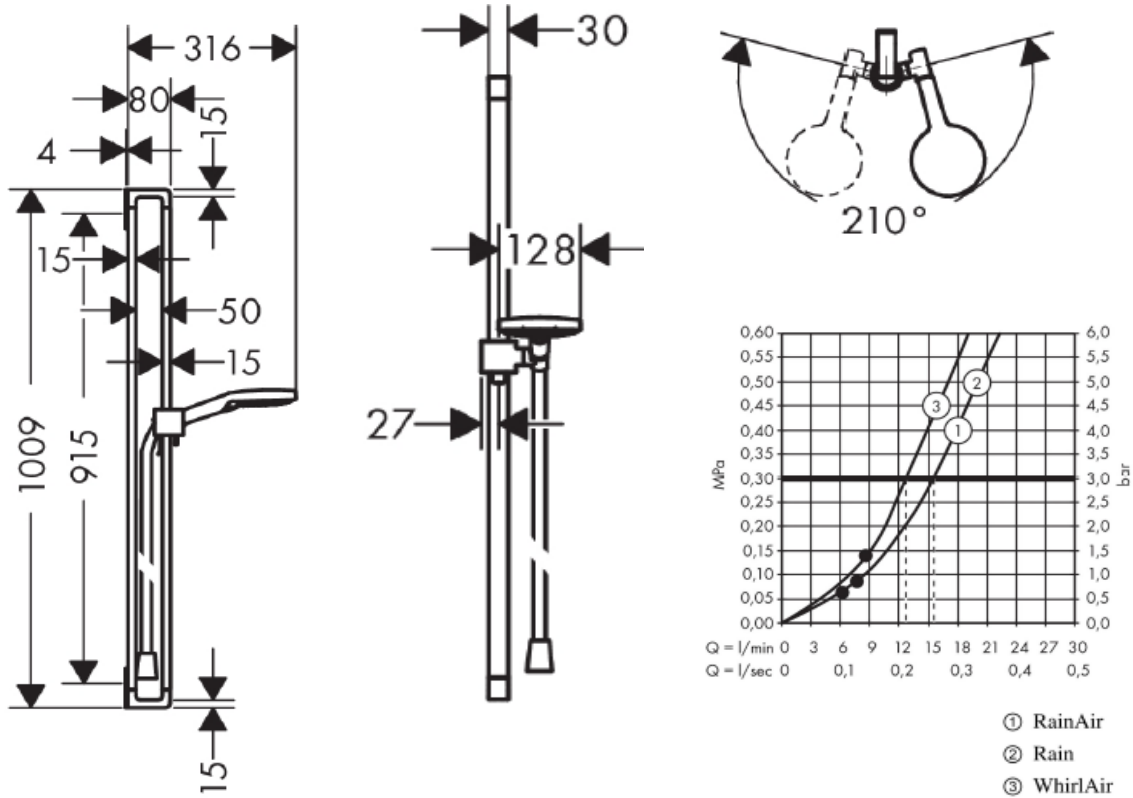

Technical Informations:



REMINDER: Pipe flushing must be done before faucets are installed. Failure to do so voids the warranty.

Do not use cleaners containing abrasive cleansers, ammonia, bleach, acids, waxes, alcohol, solvents or other products not recommended for chrome.

All information is for reference only, installation shall always be based on the actual product delivered.