

10

BABY CHANGING STATIONS

the world viewed through child's eyes



SOLUTIONS FOR BABIES AND CHILDREN SAFETY

The world seen through the eyes of the youngest children takes on another dimension with the Mediclinics solutions in this safety line for babies.

- Mediclinics' baby changing stations are manufactured under strict quality and safety standards and offer a wide range of safe, practical, functional and hygienic solutions for younger children.
- Vibrant and fun spaces to make the daily hygiene habits of babies a cheerful but also healthy time.



BABY CHANGING STATIONS babymedi

horizontal



CP0016H

material: **polypropylene**
finish: **white**

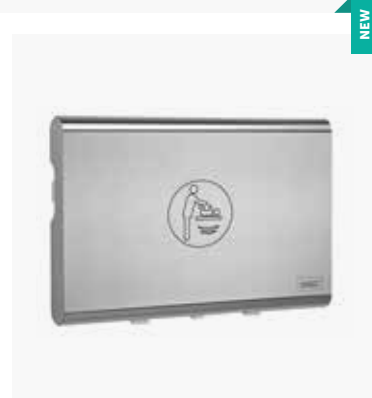

CP0016HCS

material: **polypropylene / stainless steel**
finish: **satin**



AVAILABLE IN SEPTEMBER 2016

CP0016H · CP0016HCS COMPONENTS AND MATERIALS

- Changing surface (bed) made of polypropylene with Biocote® antimicrobial additive embedded into its own surface, promoting an easy cleaning and inhibiting the growth of odor causing and staining microbes
- The open/close mechanism of the bed is always concealed to the user's view and it consists on a pair of reinforced hinges and a pneumatic cylinder, ensuring a high durability and a smooth open and close of the baby changing station
- One-piece easy-mounting chassis made of galvanized steel with the corresponding mounting hardware included, making very easy the installation of the unit to the wall
- 1,900 cm² contoured changing surface area with child protection straps made of nylon, providing a complete safety for the baby
- Bed with a pair of bag hooks (one at the right side and the other one at the left), helping to keep personal belongings close and at hand
- Liner dispenser with lock made of polypropylene, holds

- approximately 40 bed liners, minimizing operator refills and discouraging potential vandalism
- The design and manufacture of this baby changing station is according to the latest version of the EN 12221-1 ("Child use and care articles. Changing units for domestic use. Safety requirements") and EN 12221-2 ("Child use and care articles. Changing units for domestic use. Test methods") standards, assuring that the baby changing station is totally safety
- The baby changing station has been designed to hold a total weight much higher than the minimum established by the EN 12221-1 and the EN 12221-2 standards.

CP0016HCS

- One-piece frontal chassis made in AISI 304 stainless steel, 0.8 mm thick, fixed to the bottom of the bed by means of 4 bolts and 4 nuts, always concealed to the user's view, without joints or edges for increasing the user safety, a better cleaning and an easy integration with other satin-finish accessories in the restroom

Warning: To ensure that the unit supports the intended loads, baby changing station must be properly installed according to the Mediclinics' instructions.

CP0016H · CP0016HCS TECHNICAL SPECIFICATIONS

Dimensions	860 x 570 x 100 mm
Weight (empty)	10 Kg
Liner dispenser capacity	80 u.
Recommended installation height	800 mm at lowest point
Recommended installation height 	700 mm at lowest point

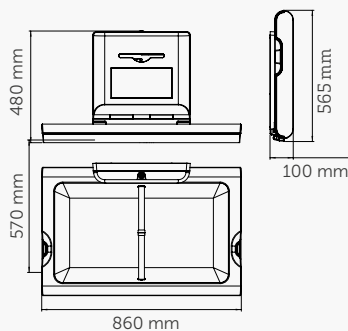

BABY CHANGING STATIONS babymedi

vertical



CP0016V

material: **polypropylene**
finish: **white**



CP0016VCS

material: **polypropylene / stainless steel**
finish: **satin**



AVAILABLE 2017

CP0016V · CP0016VS COMPONENTS AND MATERIALS

- Changing surface (bed) made of polypropylene with Biocote® antimicrobial additive embedded into its own surface, promoting an easy cleaning and inhibiting the growth of odor causing and staining microbes
- The open/close mechanism of the bed is always concealed to the user's view and it consists on a pair of reinforced hinges and a pneumatic cylinder, ensuring a high durability and a smooth open and close of the baby changing station
- One-piece easy-mounting chassis made of galvanized steel with the corresponding mounting hardware included, making very easy the installation of the unit to the wall
- 1,900 cm² contoured changing surface area with child protection straps made of nylon, providing a complete safety for the baby
- Bed with one bag hook (located in the front part of the bed), helping to keep personal belongings close and at hand
- Liner dispenser with lock made of polypropylene, holds approximately 40 bed liners, minimizing operator refills and discouraging potential vandalism
- The design and manufacture of this baby changing station is according to the latest version of the EN 12221-1 ("Child use and care articles. Changing units for domestic use. Safety requirements") and EN 12221-2 ("Child use and care articles. Changing units for domestic use. Test methods") standards, assuring that the baby changing station is totally safety
- The baby changing station has been designed to hold a total weight much higher than the minimum established by the EN 12221-1 and the EN 12221-2 standards

CP0016VCS

- One-piece frontal chassis made in AISI 304 stainless steel, fixed to the bottom of the bed by means of 4 bolts and 4 nuts, always concealed to the user's view, without joints or edges for increasing the user safety, a better cleaning and an easy integration with other satin-finish accessories in the restroom

Warning: To ensure that the unit supports the intended loads, baby changing station must be properly installed according to the Mediclinics' instructions.

CP0016V · CP0016VS TECHNICAL SPECIFICATIONS

Dimensions	875 x 553 x 100 mm
Liner dispenser capacity	80 u.
Recommended installation height	800 mm at lowest point
Recommended installation height 	700 mm at lowest point

